

Product Descriptions

MS-NF7801 is a Flocked Sampling Swab with **PP** stick used for cell & virus specimen collection, it has been designed for flu testing and nasopharyngeal clinical diagnostics. It utilizes state of the art “spray on technology” that the flocking process by means of an electro-static charge perpendicularly attaches millions of nylon microfibers on the medical grade handle tip. The flocked swab is ideal for collecting large amount of cells and rapid elution of the specimens that instantly releases the cells into the transport medium. It has been well recognized and adopted by the diagnostic test kit manufacturers who produce reagents in molecular genetics, forensics and clinical laboratories sectors. The perpendicular nylon fibers act like a soft brush, allowing the improved collection and release of both cellular and liquid samples.

Product Features

- **Ergonomic and anatomic design**, perpendicular nylon fiber acts like a soft brush thus improves patient comfort and efficiency in cell specimen collection.
- **Improved sample collection**, sprayed-on fibers statically charged and attached to the applicator tip in a uniform perpendicular manner and by means of strong capillary action cell specimens are rapidly absorbed.
- **Superior sample elution**, with an open fiber structure it instantly dislodges the specimen cells into the liquid medium, unlike traditional wound swabs when the specimen is entrapped in the mattress core.
- **Increased assay sensitivity**, flocked swabs are proven to elute >95% of the original sample rapidly thus easily resulting in improved assay sensitivity.
- **Quantitative volume transfer**, measurable and consistent uptake and transfer from patient to the test tube has no internal mattress core to disperse and entrap the precious sample like traditional fiber wound swabs.
- **Certified free of inhibitors and interference**, collection swabs are certified DNASE, RNASE-free and human DNA-free. They are also free of any PCR inhibitors, certificate of analysis available for each lot of manufacture.

Product Specifications

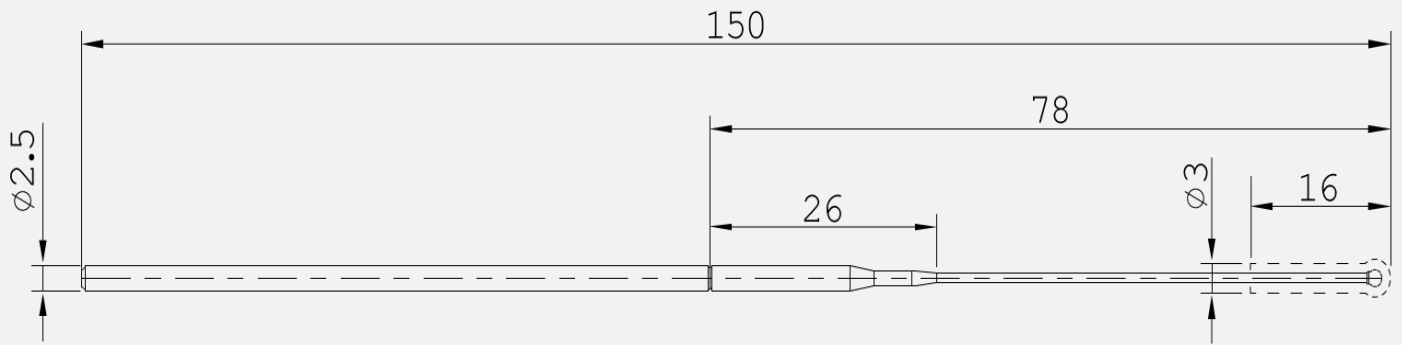

Item No.	Dimension of Flocked tip			Dimension of PP stick			
	Width	Thickness	Length	Diameter <u>1</u>	Diameter <u>2</u>	Breakpoint	Total length
MS-NF7801	3.0 mm	3.0 mm	16 mm	2.5 mm	Taper to 1.0	78mm	150 mm

Product Picture



Sterilization Process

We take EO Gas sterilization for MS-NF7801 and take Gama Ray sterilization for Transport Mediums & Kits.